

# Analysis of Passenger's Interest on Transportation of the Urban Environment in Tuban Indonesia

**Sugiyanto & Cicik Nur Indah**

*Civil Engineering Study Program, Faculty of Engineering, SunanBonang University  
Tuban East Java Indonesia*

## ABSTRACT

This study aims to determine how much influence the interest of urban environmental transport passengers in the city of Tuban, Indonesia. The interest is measured using 5 research variables consisting of transportation fares, transportation routes, waiting time for transportation orders, transportation driver services and transportation driving safety. The results of the evaluation of the outer model have met the results of the validity and reliability tests. The validity test was conducted to test whether the questions contained in the questionnaire given to the respondents were valid and able to explain the latent variables, while the reliability test was used to measure the reliability of the confidence level of the model generated in this study. The results of the evaluation of the inner model showed that the correlation number of the variable waiting time for environmental transportation messages was the most influential variable (88%), followed by vehicle driving safety by 23% and environmental transportation routes by 18%, while the other variables with the lowest effect consisted of environmental transportation driver services 2% and transportation fares have an effect on reducing by -3%.

**Keywords:** *Interest, respondents, outer model and inner model.*

## I. INTRODUCTION

In today's dynamic development, transportation is a very important (vital) need for humans, both for individual and social interests. In reality, humans need movement from one location to another, from various origins to various destinations in order to distribute products (goods) to reach consumers' locations. This mobility is carried out by using various modes of transportation, namely by means of land, river, sea, or air transportation.

The growing need for variants of transportation modes is no exception in the city of Tuban, Indonesia in accordance with the current situation and conditions. This is due to the increasing number of residents, especially in the urban environment of Tuban, thus increasing the number of needs for flexible transportation levels. As we all know, the movement of people or goods can occur due to various interests, including making a living (drivers and delivery services), tourism, services and so on. Therefore, the movement of goods for both people and goods is required to always be able to serve the various interests needed and its nature will always change both the means of transportation and the accessories to satisfy all parties.

The Tuban Regency Government through Regional Owned Enterprises in collaboration with the Department of Transportation in 2018 launched a vehicle called environmental transportation for urban areas and non-route public transportation tourism. The existence of this transportation is expected to further complement the needs of public transportation in the Tuban Regency area, especially in the development of tourism potential in the City of Tuban. The advantage of this transportation compared to other modes of transportation is that it can reach people who live in narrow alleys, residential areas, tourist destinations, can be ordered as desired and can even reach villages with a charter system from within the city to outside the city.

The emergence of urban environmental transportation is a type of transportation with the desired breakthrough is that it can be used by the community because it is practical, economical, effective, safe and comfortable. Because this transportation is non-route, the direction of destination of the users can be according to their choices and needs without having to wait long on the streets because they can be ordered directly from the homes of each user. Based on investigations and surveys in the field, it can be informed that the users are dominated by mothers and students. Some of them even use this mode of transportation with a subscription system and a shuttle system.

Based on the increasing growth of urban environmental transportation which is marked by more and more people choosing to use this transportation for various destinations, then of course there are several driving

force factors for the interest in using these services. In connection with the phenomenon that occurs, it is deemed necessary to conduct research on the analysis of passenger interest in urban environmental transportation in the City of Tuban, Indonesia.

## II. RESEARCH METHODS

The research area consists of urban areas in Tuban consisting of: Gedongombo Village, Panyuran Village, Ronggomulyo and Sendangharjo Villages, Karang Villages and Bogorejo Villages. Based on these locations can be shown on the map as follows:

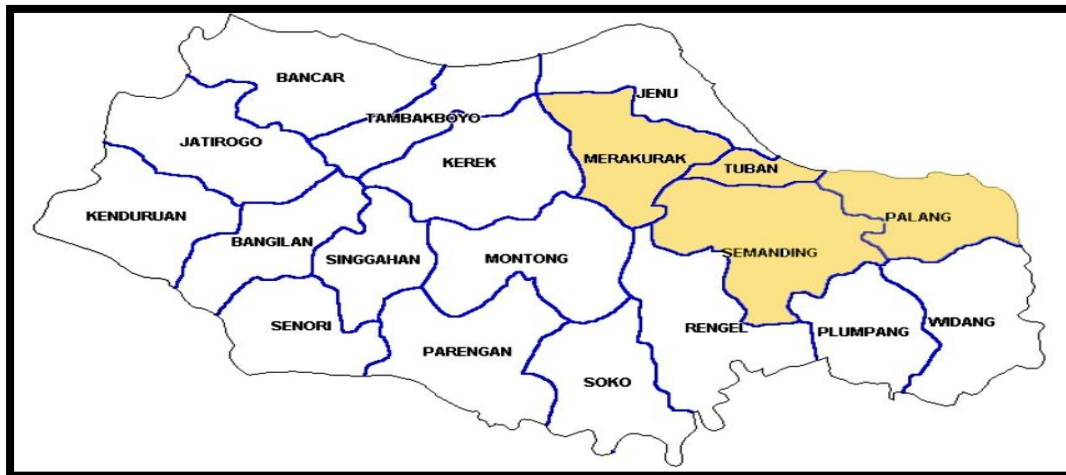

Figure 1. Map of research location

The method of data collection in the implementation of this research was carried out by distributing questionnaires to respondents. Participants who are selected to be respondents will be given a list of questions related to data that can measure passenger interest in the existence of urban environmental transportation in the areas that have been selected for research data collection. To support accuracy in data collection using a likert scale (Sugiyono, 2018). This scale is used to measure the attitudes, opinions, and perceptions of passengers about this transportation service, with a scale of 1 to 5 consisting of:

- Scale 1: Very disinterested in urban environmental transportation
- Scale 2: Not interested in urban environmental transportation
- Scale 3: Hesitating (between not interested and interested) with urban environmental transportation
- Scale 4: Interested in urban environmental transportation
- Scale 5: Very interested in urban environmental transportation

Based on the scale above, it is used to analyze the assessment of variables consisting of:

1. The independent variables (X) and the indicators used include:
  - a. Urban environmental transportation tariffs (X1), namely the nominal amount of money paid by users in using transportation services, the indicators consist of:
    - 1) Cheap, namely the cost of transportation services is considered cheap because even though more than 1 person only pays the cost of 1x trip (TA1).
    - 2) Easy, namely the way to pay is easy because you don't have to use an application, just cash is enough, so it's easier for people who are technology savvy, especially for those aged 40 and over (TA2).
    - 3) Prices are stable, namely tariffs that apply to services do not fluctuate, even if you become a subscriber you still get a discounted price (TA3).
    - 4) Prices are negotiable, namely the price for using transportation services can be negotiated based on an agreement, especially for rental or charter purposes (tourism) back and forth (TA4).
  - b. Urban environmental transportation routes (X2), namely areas that can be passed by transportation, the indicators consist of:
    - 1). Flexible, namely the area that can be reached by transportation can adjust to user needs (RA1).
    - 2) Route knowledge, namely the driver has good knowledge of the route (understanding the road) or the area intended by transportation users (RA2).

- 3) Shorter travel time (shortest route), where the driver looks for the fastest route and avoids traffic jams that are prone to congestion (RA3).
  - 4) Route coverage, which can pass through non-route routes according to the wishes of transportation service users, even narrow alleys, residential areas and other areas (RA4).
- c. The service of an urban environment transportation driver (X3), namely the attitude of courtesy, patience and friendliness of the transportation driver in serving users, the indicators consist of:
- 1) Friendly, namely the driver serves transportation users in a friendly and non-surly manner (PS1).
  - 2) Polite, namely the driver is polite in speaking and in serving users of transportation services (PS2).
  - 3) Responsiveness, which is the response or alertness of the driver to changes in routes or others from transportation service users (PS3).
  - 4) Patience, namely the attitude of the transportation driver in serving the needs of users of transportation services, including being able to wait and help carry the luggage of transportation service users (PS4).
- d. Waiting time for urban environmental transport messages (X4), which is the time required for the arrival of transportation according to the location ordered by users of transportation services, the indicators consist of:
- 1) Arrival time, which is the time taken from the time ordered until the transportation vehicle arrives at the customer's location (WT1).
  - 2) Directly to the location, namely because the transportation is private so it can come directly to serve because it does not stop or hang at certain places. The driver will immediately come to pick up passengers (WT2).
  - 3) Waiting in a relaxed manner, namely the ability of transportation that can pass through narrow alleys and residential locations, so the customer can relax and wait at their respective homes (WT3).
  - 4) Coming directly to the road, namely the time required by transportation service users when the vehicle arrives on the road and does not need to wait for other passengers or full load (WT4).
- e. Driving safety of urban environmental transportation vehicles (X5), namely the way the driver drives transportation vehicles in order to create a sense of security for users of transportation services, the indicators consist of:
- 1) Obedient to traffic, namely transportation drivers always obey traffic signs and be disciplined in driving transportation vehicles (KM1).
  - 2) Not reckless, namely the driver drives the vehicle at a moderate speed (normal), is not emotional and maintains a safe distance from other vehicles (KM2).
  - 3) Attitude in driving, namely the mental attitude of the driver in driving the vehicle to concentrate (focus) and not mess with the applications available on cell phones (KM3).
  - 4) Completeness of attributes and vehicle documents, namely the availability of complete attributes of transportation vehicles along with documents that must be fulfilled such as STNK, kir books and so on (KM4).
2. The dependent variable (Y), namely passenger interest in urban environmental transportation is measured based on the following indicators:
- a. The desire to use transportation services, namely the intention to use transportation services (K1).
  - b. Possibility of using transportation services, namely seeking information about urban environmental transportation and at some point being interested in using it (K2).
  - c. Repeat orders, namely users of transportation services can several times to fulfill their needs using transportation services (K3).
  - d. Distribution between users, namely the users of transportation services feel helped and can enjoy it so that they notify others to be able to use the transportation service (K4).

In this study, in the selected area, the respondent criteria were determined, consisting of:

1. Male and female gender
2. Age 30-60 years old
3. Place of residence in the City of Tuban, Indonesia
4. The lowest education is SMK/MA/SMA
5. Urban environmental transport users

In Solimun et al (2017) it is stated that to be able to meet the rules in determining the number of samples, it can be used to calculate sample requirements as below:

**Number of samples (M) = 50 + 8 (n)**  
 Where:  
 M : Number of variables studied  
 N : Number of variables samples

Thus, because the variables studied consist of 6 variables, the results of the calculations can be seen as follows:

Number of samples (M) = 50 + 8 (6)  
 = 98

Based on the distribution of respondents' residences in Gedongombo Village, Panyuran Village, Ronggomulyo Village, Karang Village, Sendangharjo Village, and Bogorejo Village, the number of 16-17 respondents each village is determined so that the number of samples needed is 100 respondents.

The data analysis used to measure passenger interest in urban environmental transportation in the City of Tuban consists of:

1. Descriptive analysis method  
 For the purposes of this analysis method, Microsoft Excel computer software is used to process input into the data tabulation, calculate the amount, determine the average value and others.
2. Quantitative analysis method  
 This quantitative analysis method uses partial least squares (PLS) with the application of the WarpPLS 7.0 software program, which is very suitable for conducting multivariate analysis of the influence of independent variables on the dependent variable.

### III. RESULTS AND DISCUSSION

#### 1. Characteristics of Research Respondents

Based on the information collected from the respondents, it was found that the characteristics of the respondents, consisting of age, education level, gender and type of work; as can be observed in Table 1 below:

Table 1. Characteristics of respondents

No	Respondent data	Characteristics of respondent	Total	Percentage
1	Age	16-19 years	5 peoples	5%
2		20-25 years	15 peoples	15%
3		26-30 years	14 peoples	14%
4		31-35 years	16 peoples	16%
5		36-40 years	14 peoples	14%
6		> 40 years	36 peoples	36%
Total			100 peoples	100%
1	Level of education	Primary school	4 peoples	4%
2		Junior high school	24 peoples	24%
3		Senior high school	62 peoples	62%
4		Graduated from university	10 peoples	10%
Total			100 peoples	100%
1	Gender	Man	32 peoples	32%
2		Woman	68 peoples	68%
Total			100 peoples	100%
1	Job status	Student	6 peoples	6%
2		University student	6 peoples	6%
3		Private sector employees	30 peoples	30%
4		Entrepreneur	5 peoples	5%
5		Government employees	4 peoples	4%
6		Housewife	49 peoples	49%
Total			100 peoples	100%

Source: Processed data (2021)

Based on the information in Table 1 above, the characteristics of the respondents can be explained that the most age is > 40 years old 62%, the highest education level is SMA 62%, the sex is mostly female 68% and the type of work is mostly housewives 49%.

## 2. Data Analysis and Modeling

Ghozali (2014) explains that the Partial Least Square (PLS) method is an analysis technique of all variables (multivariable) that can be used to describe the simultaneous linear relationship between observational variables, which are called latent variables consisting of independent variables and dependent variables. The independent variables consist of fare, route, driver service, message waiting time, and driving safety; while the dependent variable is the passenger's interest in environmental transportation.

Based on the involvement of the latent variables used, path analysis (block diagrams) can be performed to locate the independent variables with their dependent variables, as can be seen in Figure 2 below:

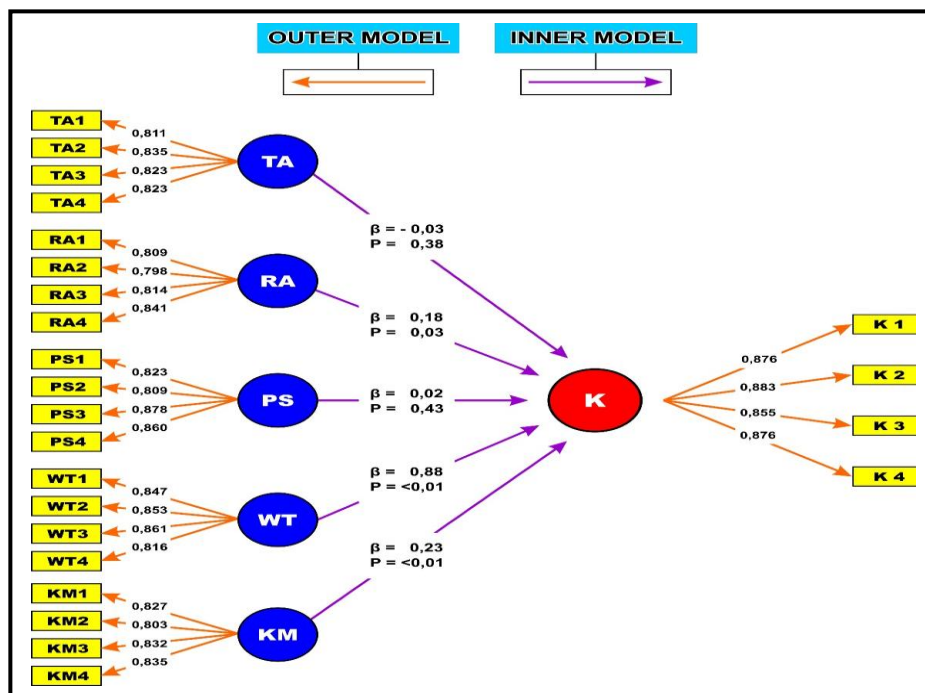

Figure 2. Results of partial least squares data processing

Based on the results of the partial least square method data processing using the WarpPLS 7.0 software as shown in Figure 2, an evaluation of the modeling obtained will then be carried out. In this study, the evaluation model formed consists of the outer model (measurement model), which explains the relationship (correlation) between the indicator and its construct and the inner model (structural model), which explains the relationship between the independent variable and the dependent variable.

## 3. Evaluation of the Outer Model (Measurement Model)

In Ghozali (2014) it is explained that the outer model is often called the outer relation or measurement model, which describes the relationship between each indicator and its latent variables. This model is also called the measurement model, which measures the depth of the relationship (correlation) between the indicators used in the study and the variables used. By getting a sufficient number of correlations (outer loading), it will be possible to generate how the indicators used are adequate or not to be used to measure research variables (constructs).

Ghozali (2014) explains that the outer model explains the relationship between construct indicators and latent variables. In this relationship, it can be evaluated based on the correlation value indicated by the value of the loading factor or outer model of the construct indicator in constructing the latent variable. From the output loading factor values, all of which are > 0.5, it can be said that they have good convergent validity. Meanwhile, based on a review of the cross-loading numbers, it can be stated that the indicators used have good discriminant validity as well. This can be identified based on the correlation value of the indicator to the construct, which is the



highest number compared to the correlation between the indicator and other constructs. From the loading factor value, the ability of construct indicators can be tested in explaining the latent variables. Therefore, the evaluation of this model involves testing consisting of a validity test and a reliability test as described below:

#### 1. Validity Test

This test was conducted to test whether the questions contained in the questionnaire given to the respondents were valid and able to explain the latent variables. In conducting the validity test, it is determined by the following 2 (two) things:

##### a. Convergent Validity

The results of the indicator validity test in this study have a loading factor number that can be used to validate the latent construct. In this study, there are 6 latent constructs with a total of 24 indicators using a likert scale with an interval rating of 1 to 5. Based on the test results, the loading factor value can be seen in Table 2 below:

Table 2. Testing the value of loading factor

Variables	Code	Indicators	Loading factor
Rate (X1)	TA1	The cost of transportation services is considered cheap because even if more than 1 person only pays for 1x trip only	0.811
	TA2	How to pay, you don't have to use an application, just cash is enough, so for people who are technology stuttering it's easier, especially for those aged 40 and over	0.835
	TA3	The rates that apply to services do not fluctuate, even if you become a subscription you still get a discount	0.823
	TA4	Prices for using transportation services can be negotiated based on an agreement, especially for rental or charter purposes (tourism) back and forth	0.823
Travel route (X2)	RA1	The area covered by transportation is flexible enough to adapt to user needs	0.809
	RA2	The driver has good knowledge of the route (understands the road) or the area targeted by transportation users	0.798
	RA3	Shorter travel time (shortest route) looking for a route that is prone to congestion	0.814
	RA4	Route coverage can pass through non-route routes according to the wishes of transportation service users, even entering narrow alleys, residential areas and other areas.	0.841
Driver service (X3)	PS1	The driver serves transportation users in a friendly and not sour face	0.823
	PS2	The driver is polite in speaking and acting in serving transportation service users	0.809
	PS3	Responsiveness or the readiness of the driver to change routes or others from users of transportation services	0.878
	PS4	The attitude of the transportation driver in serving the needs of service users is quite patient, including being able to wait and help carry the luggage of service users	0.860
Waiting time (X4)	WT1	Arrival time required from ordering until the vehicle arrives at the customer's location	0.847
	WT2	Transportation is personal so it can come to serve immediately because it does not stop or hang at certain places. The driver will immediately come to pick up the passengers	0.853
	WT3	The ability of transportation that can pass through narrow alleys and residential locations, so customers can relax and wait in their respective homes	0.861
	WT4	The time required by service users when the vehicle arrives on the road and does not need to wait for other passengers or a full load	0.816
Driving safety (X5)	KM1	Transport drivers always obey traffic signs and be disciplined in driving vehicles	0.827
	KM2	The driver drives the vehicle at a moderate (normal) speed without being reckless, unemotional and maintaining a safe distance from other vehicles	0.803
	KM3	The mental attitude of the driver in driving the vehicle to concentrate (focus) and not play with cell phones	0.832

	KM4	Availability of completeness of vehicle attributes along with documents that must be fulfilled such as vehicle registration certificate, vehicle test books and so on	0.835
Passenger interest (Y)	K1	Desire to use urban environmental transportation services	0.876
	K2	Looking for information about environmental transport and interested in using it	0.883
	K3	Repeat orders or users of environmental transportation services can use environmental transportation services several times	0.855
	K4	The users of transportation services feel helped and can enjoy it so that they tell others to be able to use these transportation services	0.876

Source: Processed data (2021)

From a review of the loading factor figures, it can be identified how strong the relationship between the indicators is to each latent construct (latent variable). In another sense, it can be explained that the loading factor value describes how strong the correlation between construct indicators and latent variables is. Based on the results of data processing (output) as shown in Figure 2 about the model in this study and Table 2 about testing the loading factor value, it can be shown that all indicators have a loading factor value above 0.6. With the acquisition of the values obtained, it means that all indicators show valid validity test results (Ghozali, 2014). Thus, the interpretation of the question indicators used in the questionnaire is valid because it is relevant because it can explain and be able to measure the latent variables.

b. Discriminant Validity

A review of discriminant validity figures is needed to identify significantly the highest loading factor number in the resulting construct compared to the loading factor with other constructs. Ghozali (2014) provides guidelines on the inner model with reflective indicators tested using cross loading numbers. The mechanism is by knowing the magnitude of the effect (correlation) of the variable (construct) if it has a higher correlation test result than other variables, then this proves that the variable can measure its own block better than other blocks, as shown in Table 3 below:

Table 3. Cross loading value between latent variables

The value of the loading factor of the variables used in the study						
Code	X1	X2	X3	X4	X5	Y
TA1	0.811	-0.566	-0.286	0.433	0.616	-0.407
TA2	0.835	-0.054	0.178	-0.369	0.099	0.118
TA3	0.823	0.446	0.041	-0.001	-0.463	0.225
TA4	0.823	0.165	0.061	-0.051	-0.244	0.057
RA1	-0.062	0.809	0.238	0.085	0.143	-0.066
RA2	-0.121	0.798	-0.110	-0.378	0.410	-0.110
RA3	0.176	0.814	-0.349	0.182	-0.123	-0.116
RA4	0.004	0.841	0.213	0.100	-0.408	0.279
PS1	0.120	0.056	0.823	-0.016	-0.172	0.042
PS2	0.027	-0.001	0.809	-0.314	0.395	-0.196
PS3	-0.120	-0.267	0.878	0.190	0.151	0.073
PS4	-0.018	0.220	0.860	0.117	-0.362	0.070
WT1	-0.004	0.109	0.119	0.847	-0.238	-0.036
WT2	0.099	-0.029	-0.142	0.853	-0.261	0.063
WT3	0.137	0.075	0.086	0.861	0.085	-0.225

WT4	-0.244	-0.161	-0.065	0.816	0.430	0.210
KM1	-0.039	0.094	0.364	-0.480	0.827	0.224
KM2	-0.081	0.065	-0.612	0.443	0.803	-0.127
KM3	0.185	0.168	-0.061	0.033	0.832	-0.314
KM4	-0.067	-0.323	0.289	0.016	0.835	0.214
K1	0.122	-0.003	-0.048	0.005	-0.029	0.876
K2	-0.023	-0.129	-0.134	0.051	0.050	0.883
K3	-0.197	0.050	0.196	0.373	-0.007	0.855
K4	0.093	0.084	-0.008	-0.420	-0.015	0.876

Source: WarpPLS7.0 data processing output (2021)

Based on the data information in Table 3 above, it can be shown from the evaluation of the comparison of the cross loading values resulting in good discriminant validity because the correlation value of the indicator to the construct is higher than the correlation value of the indicator with other constructs. Thus, it can be explained that an indicator that is already a member of a certain variable, may not be a member of another variable.

2. Reliability Test

Reliability test is used to measure the reliability of the confidence level of the resulting model on the results of research data processing. In the reliability test, there are 3 parameter benchmark values to determine whether they are reliable or not, which consist of composite reliability, cronbach's alpha and average variance extracted (AVE). Based on these test parameters, the modeling generated in the implementation of this research can be explained as follows:

a. Composite reliability and cronbach's alpha

Based on the results of data processing, in the evaluation of the outer model, construct reliability tests can be carried out based on the value of composite reliability and cronbach's alpha from the indicator block that measures the construct. The following are the results of testing composite reliability and cronbach's alpha from the WrapPLS 7.0 output presented in Table 4 as follows:

Table 4. Composite Reliability and Cronbach's Alpha

Construct (LatenVariables)	Composite Reliability	Cronbach's Alpha
Rate (X1)	0.894	0.841
Travel route (X2)	0.888	0.832
Driving service (X3)	0.907	0.864
Waiting time (X4)	0.909	0.866
Driving safety (X5)	0.894	0.843
Passenger interest (Y)	0.927	0.895

Source: WarpPLS7.0 data processing output (2021)

Based on Ghozali (2014), a guideline is given that a construct is said to be reliable if it has a composite reliability value above 0.70 and cronbach's alpha above 0.60. Based on the results of data processing output using WrapPLS7.0 presented in Table 4, it was found that all constructs in this study had a composite reliability value above 0.70 and cronbach's alpha above 0.60. Thus, the indicators used in the questionnaire are reliable (reliable). A more in-depth interpretation can be explained as follows:

- 1) Based on the composite reliability value above 0.7, it shows that the latent variables used in this study have reliable reliability to test the research hypothesis.
- 2) Based on cronbach's alpha value above 0.6, it shows a fairly good level of consistency of answers from respondents to the questions in the questionnaire distributed to all respondents.

b. Average variance extracted (AVE)

The WrapPLS7.0 output results show the average variance extracted (AVE) value shown in Table 5 as follows:



Table 5. Average variance extracted (AVE) value

Construct (Laten Variables)	AVE Value	AVE Benchmark Value	Description
Rate (X1)	0.677	0.5	Reliable
Travel route (X2)	0.665	0.5	Reliable
Driving service (X3)	0.711	0.5	Reliable
Waiting time (X4)	0.713	0.5	Reliable
Driving safety (X5)	0.679	0.5	Reliable
Passenger interest (Y)	0.761	0.5	Reliable

Source: WarpPLS7.0 data processing output (2021)

Based on the output of the AVE value as shown in Table 5, all construct variables showed values above 0.50. With the achievement of these parameter values, the results of the evaluation of the outer model show that it meets the reliability test (reliable) Ghozali, (2014). The interpretation in more depth can be explained that the indicators in this study have met the criteria for discriminant validity, in the sense that if certain indicators are included in certain variables, it is unlikely that they will become part or members of other variables (mutually exclusive).

#### 4. Evaluation of the Inner Model (Structural Model)

Ghozali (2014) states that the inner model which is sometimes also called the inner relation, structural model or substantive theory describes the relationship between latent variables, which can be evaluated as follows:

##### 1. Structural model testing (influence test)

The structural model in WarpPLS7.0 is evaluated based on the value of the regression coefficient ( $\beta$ ) for the dependent variable and the path coefficient value for the independent variable which is then assessed for significance based on the P value of each path. In the inner model, this is also known as the influence test, in the sense of how the independent variable (independent variable) affects the dependent variable (dependent variable). Besides that, whether this influence can be proven significantly (significant) or not by looking at the p value compared to the p value table. As for explaining the structural model in this study, it can be seen through the WarpPLS7.0 output in Table 6 below:

Table 6. Influence test based on regression coefficient value ( $\beta$ )

Construct (Laten Variables)	Regression Coefficient Value( $\beta$ )	Influence Percentage
Rate (X1)	- 0,03	-3%
Travel route (X2)	0.18	18%
Driving service (X3)	0.02	2%
Waiting time (X4)	0.88	88%
Driving safety (X5)	0.23	23%

Source: WarpPLS7.0 data processing output (2021)

Based on the value of the regression coefficient ( $\beta$ ) obtained in this study as shown in Table 6, the parameter values for all constructs have 1 negative value and 4 positive values. With the achievement of the majority of positive coefficient values, it can be seen that there is an increasing effect on the factors of passenger interest in urban environmental transportation. Because of this, a more in-depth interpretation can be explained as follows:

- Urban environmental transport fares have an effect of -3% lowering the interest of the passengers.
- Urban environmental transportation routes have an increasing effect of 18% on passenger interest.
- The service of an urban environment transportation driver has an effect of increasing by 2% on the interest of its passengers.
- Waiting time for urban environmental transportation messages has an increasing effect of 88% on passenger interest.
- Driving safety of urban environmental transportation vehicles has an increasing effect of 23% on the interest of its passengers.

Based on the results of testing the structural model as described above, it can be concluded that the regression equation is as follows:

$$\text{Passenger interest (Y)} = -3\% \text{ Transport fare (X1)} + 18\% \text{ Transport route (X2)} + 2\% \text{ Driver service (X3)} + 88\% \text{ Transport order waiting time (X4)} + 23\% \text{ Vehicle driving safety (X5)}$$

2. Test the significance of the effect

In testing the structural model, it can be proven that there is an influence on all factors of passenger interest in environmental transportation in Tuban City. Based on the test results, further testing is still needed to obtain more convincing information whether the effect is significant (real) or only pseudo (not significant). In another sense, whether there is an effect indicated by a correlation value will need to be proven again whether the influence is real or is it just a coincidence. To test the significance of the effect of the independent variable on the dependent variable in the study, it can be shown in Table 7 as follows:

Table 7. Test the significance of the effect based on P Value

Construct (Laten Variables)	P Value	Test level			Significance test results
		α=10%	α=5%	α=1%	
Rate (X1)	0.38	0,1	0,05	0,01	Not significant
Travel route (X2)	0,03	0,1	0,05	0,01	Significant
Driving service (X3)	0.43	0,1	0,05	0,01	Not significant
Waiting time (X4)	< 0.01	0,1	0,05	0,01	Significant
Driving safety (X5)	< 0.01	0,1	0,05	0,01	Significant

Source: WarpPLS7.0 data processing output (2021)

The significance test can be done by looking at the comparison of the P value with the value of (test level) at the error rate =10%, =5% and =1%. Based on the P value obtained in the inner model of the data processing results in this study, if the parameter value is smaller than the value, it can be said that the influence of the independent variable in explaining (affecting) the dependent variable is significant (real) (Ghozali, 2014). As shown in Table 7 above, at the error test level =10% and =5% it can be seen that the construct (latent variable) that can be proven is passenger interest in urban environmental transportation, has a significant effect consisting of: variable transportation routes, waiting times and driving safety. As for the variable of transportation tariffs and driver services, the effect is not significant (not real or pseudo).

Based on the results of the influence test obtained, the results of the analysis can be used to test the research hypothesis, as can be observed in Table 8 below:

Table 8. Research Hypothesis Test Results

Research Hypothesis	Effect Test Results	Description
H1: Urban environmental transportation fares have a significant effect on passenger interest	Nosignificant effect	Rejected
H2: Urban environmental transportation routes have a significant effect on passenger interest	Significant effect	Accepted
H3: The service of an urban environment transportation driver has a significant effect on the interest of its passengers	Nosignificant effect	Rejected
H4: Order waiting time has a significant effect on the interest of urban environment transportation passengers	Significant effect	Accepted
H5: The safety of driving an urban environment transportation vehicle has a significant effect on the interest of its passengers	Significant effect	Accepted

Based on the results of hypothesis testing in this study as can be observed in Table 8 above, the interpretation can be explained as follows:

1. The effect of the transportation fare factor on the interest of urban environmental transportation passengers (H1 is rejected), showing the test results are not significant, in the sense that the influence of these factors cannot be proven and is not real (pseudo).
2. The influence of the transportation route factor on the interest of urban environmental transportation passengers (H2 is accepted), shows the test results of a significant effect, in the sense that the influence of these factors can be proven and is real.
3. The influence of the service factor of the urban environment transportation driver on the interest of the passengers (H3 is rejected), showing the test results are not significant, in the sense that the influence of these factors cannot be proven and is not real (pseudo).

4. The effect of the waiting time factor for ordering on the interest of urban environmental transport passengers (H4) is accepted, showing a significant effect test result, in the sense that the influence of these factors can be proven and is real.
5. The influence of the safety factor of driving an urban environment transportation vehicle on the interest of its passengers (H5 is accepted), shows the test results of a significant effect, in the sense that the influence of these factors can be proven and is real.

#### IV. CONCLUSION

Based on the analysis of passenger interest in urban environmental transportation in Tuban Indonesia, conclusions can be drawn:

1. Based on the evaluation of the outer model, the indicators and variables used meet the validity and reliability tests. This means that the questions contained in the questionnaire given to the respondents are valid and able to explain the latent variables and can be used to measure the reliability of the resulting model's confidence level.
2. Based on the results of the analysis of passenger interest in urban environmental transportation (evaluation of the inner model) it was found that message waiting time was the most influential variable, namely 88%, followed by driving safety 23% and route 18%, while the lowest influential variable consisted of driver service 2 % and the rate of effect decreases by -3%.

#### REFERENCES

- [1.] Ghozali, I. (2014). Structural Equation Modeling:Metode Alternatif dengan Partial LeastSquare (PLS). Fourth edition. Diponegoro University Publishing Agency, Semarang Indonesia.
- [2.] Solimun, Achmad; Reinaldo Fernandes and Nurjannah. (2017). Metode Statistika Multivariat: Pemodelan Persamaan Struktural (SEM)-Pendekatan WarpPLS (1st edition.). Brawijaya University Press, Malang Indonesia.
- [3.] Sugiyono. (2018). Metode Penelitian Kuantitatif, Kualitatif, dan R&D. Alfa Beta Publishing, Bandung Indonesia.